



BRAVO SOSTIENE L'ASSOCIAZIONE RETINOSTOP
NELLA RICERCA CONTRO IL RETINOBLASTOMA



Patamix

by *Cristophe Adam*

The pâte à choux machine



patamix

by *Cristophe Adam*

For a perfect Pâte à Choux

After macarons, the new trendy products of global pastry making - such as éclairs - require a perfect pâte à choux. This is why one of their gurus, **Cristophe Adam**, has set out to devise, together with **Bravo**, a technological solution for pastry chefs to be always one step ahead!





Description

Patamix is the brand-new Bravo technology developed exclusively for the preparation of pâte à chou! It features 2 automatic programmes:

- Traditional pâte à chou method;
- Pâte à chou preparation following **Christophe Adam's** recipes.

The machine stands out for its innovative mixing system: the combined motion of its fixed and mobile parts ensures an unprecedented texture of the finished product. All processing phases take place inside the machine: from feeding in raw materials, to heating and baking, as well as the preparation of a perfectly smooth mixture. The working cycle takes about one hour and yields 50 Kg of product.

The high-performance **Patamix** technology allows professional pastry chefs to work according to their needs: they can both choose a half-load working mode and run repeated consecutive cycles without having to clean the machine in between them.

Advantages and strengths

- No water consumption for cooling.
- Shorter production times.

Technical features

- Available in model 50 (50 Kg of product per cycle).
- Stainless steel upper grille for sifting flour.

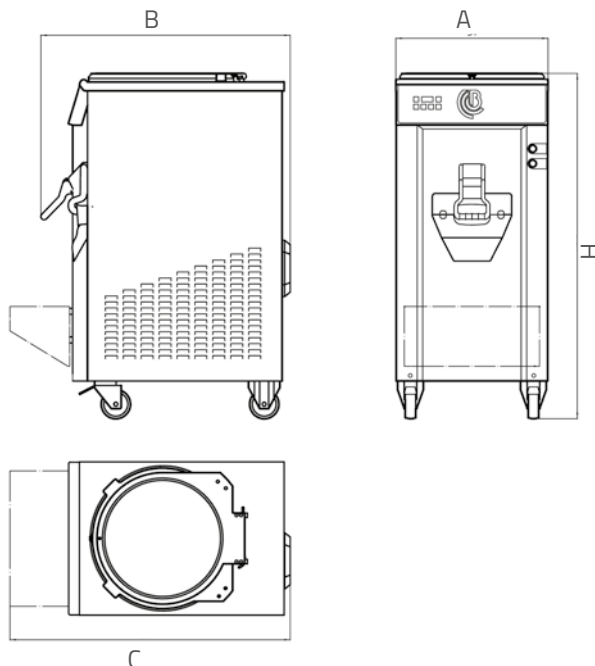

TECHNICAL DATA		50
Min mixture *1	Kg/ciclo	25
Max mixture *1	Kg/ciclo	50
Voltage *2	Volt/Hz/Ph	400/50/3
Max. power	kW	9,7
Width (A)	cm	51
Depth (B)	cm	83,6
Depth (C)	cm	93,9
Height (H)	cm	115,6
Weight	kg	140

*1 Hourly production may change accordingly to type of mixture and finished product density.

*2 Also available in 60Hz.